

REV	DESCRIPTION	DATE	ECN NO.	CHANGER
A-0	DRAWING RELEASE	14.12.16		

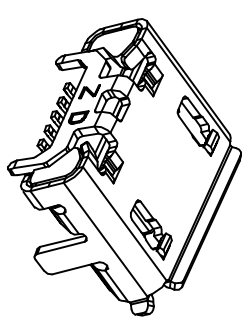
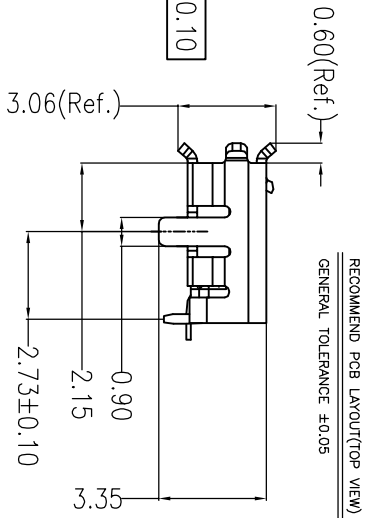
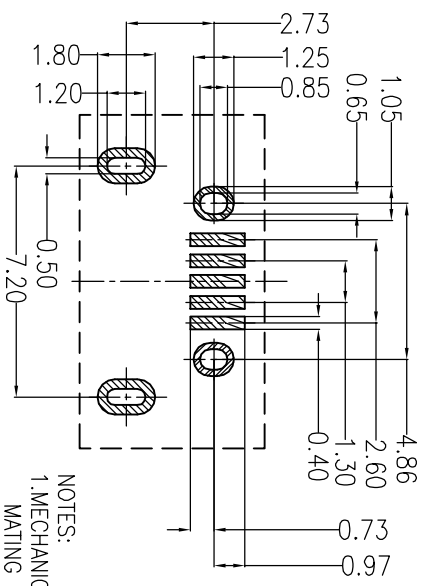
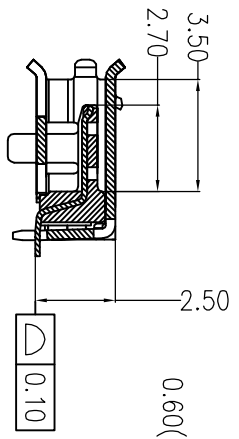
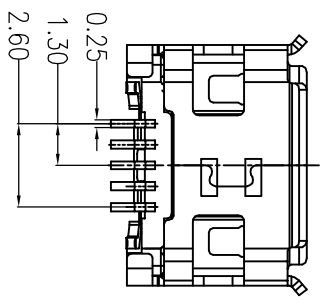
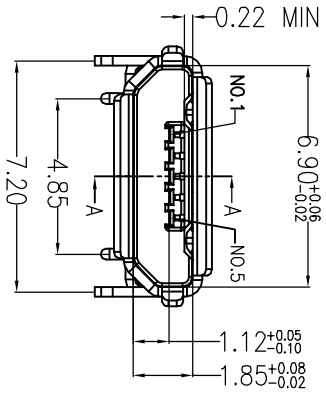
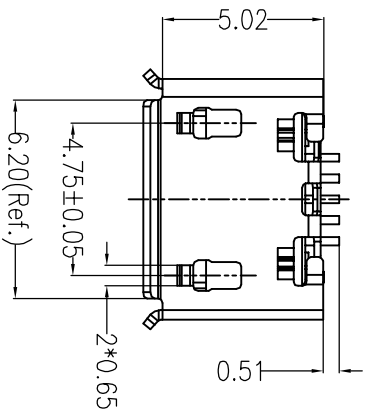

- NOTES:
- MECHANICAL:
 - MATING FORCE: 35N MAX.
 - UNMATING FORCE: 10N MIN, INITIAL.
 - 8~20N AFTER 10000 CYCLES.
 - ELECTRICAL:
 - DURABILITY: 5000 CYCLES MIN.
 - CURRENT: 1.0A
 - VOLTAGE: 30V MAX
 - WITHSTANDING VOLTAGE: 100V AC
 - CONTACT RESISTANCE: 30 mΩ MAX INITIAL;
 - 40 mΩ MAX AFTER 10000 CYCLES
 - ENVIRONMENTAL
 - OPERATING TEMPERATURE RANGE -30°C ~ +80°C
 - 4. SALT SPRAY : 24 H AT 35%DC WITH 5%-SALT-SOLUTION CONCENTRATION.
 - 5. PRODUCT SPEC:SP-MICRO USB-001
 - 6. PACKAGE SPEC:DWG-PK MUB-0XX
 - 7. PRODUCT MEET FOR ROHS STANDARD

NO.	NAME	MATERIAL	QTY	REMARK
3	SHELL	SUS 304	1	T=0.30mm Plating SM40~160U"
2	InsertMolding	LCP	1	UL94V-0
1	TERMINAL A	C2680	5	T=0.15mm Au/Ni Plated

CZT DONGGUAN ZHENGDE (YIHUA) CONNECTOR CO., LTD

CUSTOMER DRAWING	REV:	APPD:	D/N:	SHEET:	P/N:
X: ±0.38 X: ±0.25 .XX±0.20 .XXX±0.10	X: ±0.4 X: ±2 .XX .XXX	Dragon Dragon	5215-0024	1/1	10336105A026